

GEOTILL Inc.

Geotechnical Engineering • Subsurface Exploration • Environmental Services • Construction Testing and Material Engineering

GEOTECHNICAL ENGINEERING LIBRARY

[GEOTILL](#)

USA



GEOTILL

ENGINEERING, INC.

Phone 317-449-0033 Fax 317- 285-0609

info@geotill.com

Toll Free: 844-GEOTILL

Geotechnical, Environmental and Construction Materials Testing Professionals

www.geotill.com

Offices Covering all USA

UNIVERSITY OF WASHINGTON
DEPARTMENT OF CONSTRUCTION MANAGEMENT

CM 420
TEMPORARY STRUCTURES

Winter Quarter 2007

Professor Kamran M. Nemati

Temporary Structures

Cofferdams



CM 420

TEMPORARY STRUCTURES

Lesson 4: Cofferdams

Overview

A cofferdam is a temporary structure designed to keep water and/or soil out of the excavation in which a bridge pier or other structure is built. When construction must take place below the water level, a cofferdam is built to give workers a dry work environment. Sheet piling is driven around the work site, seal concrete is placed into the bottom to prevent water from seeping in from underneath the sheet piling, and the water is pumped out. The word "cofferdam" comes from "coffer" meaning box, in other words a dam in the shape of a box. This lesson covers structural cofferdams as temporary installation, explaining in step-by-step detail proper and safe methods and materials to be used. There are different types of cofferdam, some are used to support excavation operation and some are enclosed type box placed in the water. The focus of this lesson is on the latter type.

Lesson Objectives

By the end of this lesson you will be able to:

- describe cofferdams and when they are used on construction projects;
- describe the forces on cofferdams
- explain design considerations;
- recognize the importance of sealing the bottom of cofferdams

Reading Assignment

Class notes

Optional reading: Ratay, Chapter 7 "Cofferdams".

1. INTRODUCTION

- Cofferdams are temporary enclosures to keep out water and soil so as to permit dewatering and construction of the permanent facility (structure) in the dry.
- A cofferdam involves the interaction of the structure, soil, and water. The loads imposed include the hydrostatic forces of the water, as well as the dynamic forces due to currents and waves.
- In construction of cofferdams maintaining close tolerances is difficult since cofferdams are usually constructed offshore and sometimes under severe weather conditions. Under these circumstances, significant deformations of cofferdam elements may happen during the course of construction, and therefore it may be necessary to deviate from the design dimensions in order to complete the project according to plan.
- The loads imposed on the cofferdam structure by construction equipment and operations must be considered, both during installation of the cofferdam and during construction of the structure itself.
- Removal of the cofferdam must be planned and executed with the same degree of care as its installation, on a stage-by-stage basis. The effect of the removal on the permanent structure must also be considered. For this reason, sheet piles extending below the permanent structure are often cut off and left in place, since their removal may damage the foundation soils adjacent to the structure.
- In cofferdam construction, safety is a paramount concern, since workers will be exposed to the hazard of flooding and collapse.
- Safety requires that every cofferdam and every part thereof shall be of suitable design and construction, of suitable and sound material and of sufficient strength and capacity for the purpose for which it is used, proper construction, verification that the structure is being constructed as planned, monitoring the behavior of the cofferdam and surrounding area, provision of adequate access, light and ventilation, and attention to safe practices on the part of all workers and supervisors, and shall be properly maintained.

Types of cofferdam:

1. **Braced:** It is formed from a single wall of sheet piling which is driven into the ground to form a “box” around the excavation site. The box is then braced on the inside and the interior is dewatered. It is primarily used for bridge piers in shallow water (30 - 35 ft depth)
2. **Earth-Type:** It is the simplest type of cofferdam. It consists of an earth bank with a clay core or vertical sheet piling enclosing the excavation. It is used for low-level waters with low velocity and easily scoured by water rising over the top.
3. **Timber Crib:** Constructed on land and floated into place. Lower portion of each cell is matched with contour of river bed. It uses rock ballast and soil to decrease seepage and sink into place, also known as “Gravity Dam”. It usually consists of 12’x12’ cells and is used in rapid currents or on rocky river beds. It must be properly designed to resist lateral forces such as tipping / overturning and sliding.
4. **Double-Walled Sheet Pile:** They are double wall cofferdams comprising two parallel rows of sheet piles driven into the ground and connected together by a system of tie rods at one or more levels. The space between the walls is generally filled with granular material such as sand, gravel or broken rock.

5. **Cellular:** Cellular cofferdams are used only in those circumstances where the excavation size precludes the use of cross-excavation bracing. In this case, the cofferdam must be stable by virtue of its own resistance to lateral forces.

Advantages of Cofferdam

Performing work over water has always been more difficult and costly than performing the same work on land. And when the work is performed below water, the difficulties and cost difference can increase geometrically with the depth at which the work is performed. The key to performing marine construction work efficiently is to minimize work over water, and perform as much of the work as possible on land. Below some of the advantages of cofferdams are listed:

- Allow excavation and construction of structures in otherwise poor environment
- Provides safe environment to work
- Contractors typically have design responsibility
- Steel sheet piles are easily installed and removed
- Materials can typically be reused on other projects

Installation

The success of any piling scheme requires satisfactory completion of the following stages.

1. Competent site investigation, sampling and relevant testing to build up an informed picture of the task.
2. Adequate design of all the stages of the construction.
3. Setting out and installation of the piles.

As with all site operations the relevant legislation and guidance on matters pertaining to safety must be strictly adhered to. Items needed for installation are pile driving hammer (vibratory or impact), crane of sufficient size, steel sheet piles are typically used, H-piles and/or wide-flange beams for wales and stringers. In many cases barges may be required for efficient installation of cofferdams.

2. TYPES OF IMPOSED LOADS

A typical cofferdam will experience several loading conditions as it is being build and during the various construction stages. The significant forces are hydrostatic pressure, forces due to soil loads, water current forces, wave forces, ice forces, seismic loads and accidental loads. In order to over come the displaced water buoyancy, the tremie seal thickness is about equal to the dewatered depth. Figure below shows a typical cofferdam schematic.

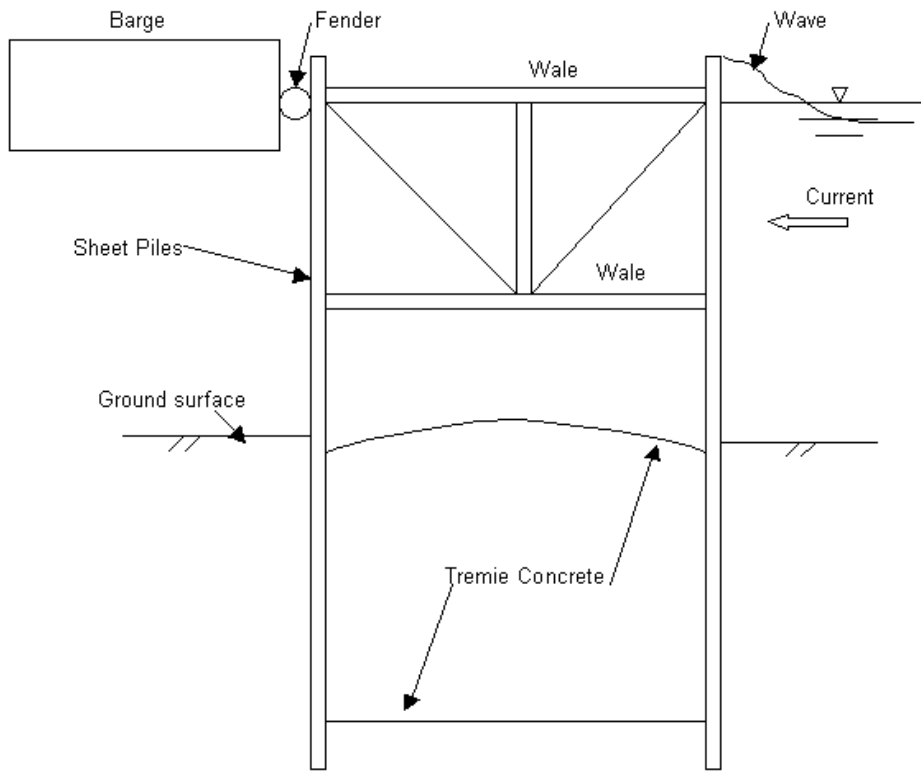

Figure 0 – Typical cofferdam schematic

Hydrostatic pressure

The maximum probable height outside the cofferdam during construction and the water height inside the cofferdam during various stages of construction need to be considered. These result in the net design pressure shown in Fig. 1 below:

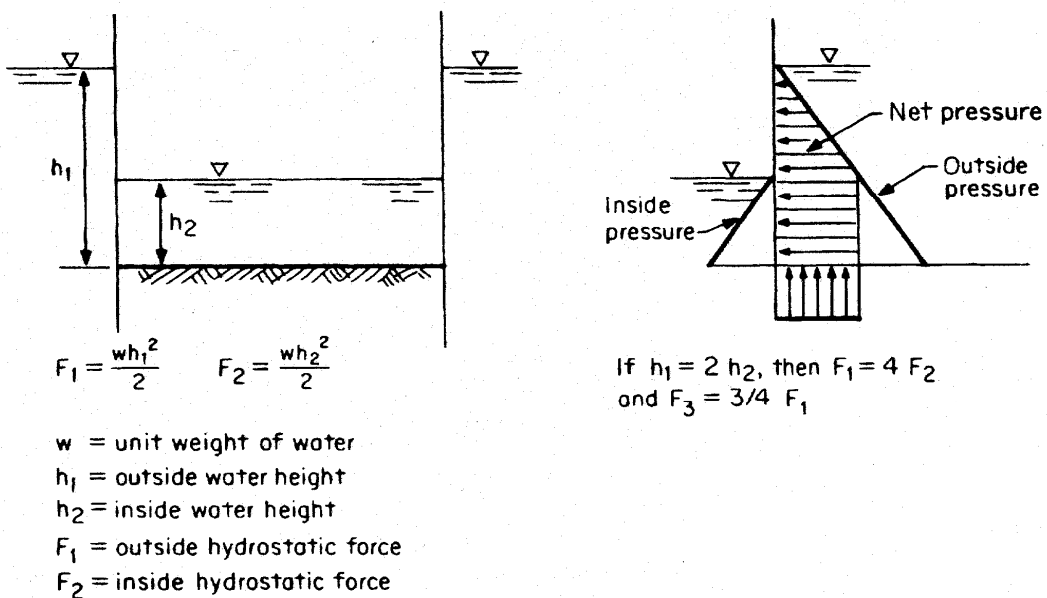

Figure 1 - Hydrostatic forces on partially dewatered cofferdam

Forces due to Soil Loads

The soils impose forces, both locally on the wall of the cofferdam and globally upon the structure as a whole. These forces are additive to the hydrostatic forces.

Local forces are a major component of the lateral force on sheet-pile walls, causing bending in the sheets, bending in the wales, and axial compression in the struts (see Fig. 2).

Figure 2 - Soil force in typical weak muds or clays

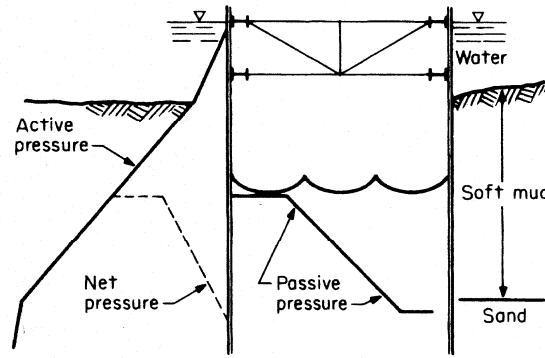

Current Forces on Structure

With a typical cofferdam, the current force consists not only the force acting on the normal projection of the cofferdam but also on the drag force acting along the sides. With flat sheet piles, the latter may be relatively small, whereas with z-piles it may be substantial, since the current will be forming eddies behind each indentation of profile, as shown in Fig. 3.

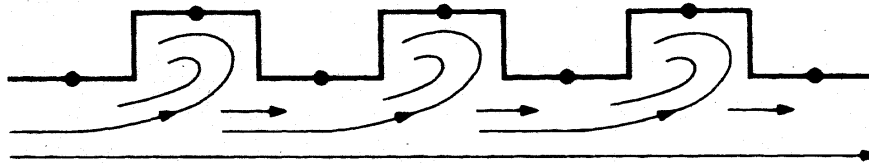

Figure 3 – Current flow along sheet piles

Wave forces

Waves acting on a cofferdam are usually the result of local winds acting over a restricted fetch and hence are of short wavelength and limited to height. However, in some cases the cofferdam should have at least three feet of freeboard or higher above the design high water elevation than the maximum expected wave height. Wave forces will be significant factor in large bays and lakes where the fetch is several miles. Passing boats and ships, especially in a restricted waterway, can also produce waves. The force generated by waves is asymmetrical and must be carried to the ground through the sheet piling in shear and bending. The waler system must be designed to transmit the wave forces to the sheet piles.

Ice forces

These are of two types: the force exerted by the expansion of a closed-in solidly frozen-over area of water surface (static ice force) and the forces exerted by the moving ice on breakup (dynamic ice force). As an example, for static ice force, a value of 4000 lb/ft² has been used on cofferdams and structures on the great Lakes, whereas the value due to dynamic ice force on a cofferdam-type structure are often taken at 12,000 to 14,000 lb/ft² of contact area.

Seismic Loads

These have not been normally considered in design of temporary structures in the past. For very large, important, and deep cofferdams in highly seismically active areas, seismic evaluation should be performed.

Accidental loads

These are the loads usually caused by construction equipment working alongside the cofferdam and impacting on it under the action of waves.

3. Scour:

Scour of the river bottom or seafloor along the cofferdam may take place owing to river currents, tidal currents, or wave-induced currents. Some of the most serious and disastrous cases have occurred when these currents have acted concurrently.

A very practical method of preventing scour is to deposit a blanket of crushed rock or heavy gravel around the cofferdam, either before or immediately after the cofferdam sheet piles are set. A more sophisticated method is to lay a mattress of filter fabric, covering it with rock to hold it in place.

4. COFFERDAM COMPONENTS:

- Sheet piling

Sheet piling is a manufactured construction product with a mechanical connection “interlock” at both ends of the section. These mechanical connections interlock with one another to form a continuous wall of sheeting. Sheet pile applications are typically designed to create a rigid barrier for earth and water, while resisting the lateral pressures of those bending forces. The shape or geometry of a section lends to the structural strength. In addition, the soil in which the section is driven has numerous mechanical properties that can affect the performance.

- Bracing frame

- Concrete seal

The typical cofferdam, such as a bridge pier, consists of sheet piles set around a bracing frame and driven into the soil sufficiently far to develop vertical and lateral support and to cut off the flow of soil and, in some cases the flow of water (Fig. 4).

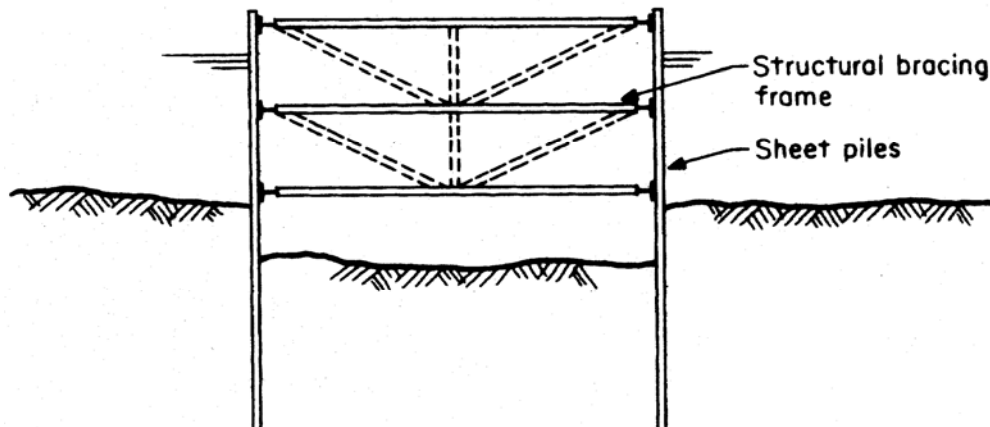

Figure 4 – Typical cofferdam without seal or pile

The structure inside may be founded directly on rock or firm soil or may require pile foundations. In the latter case, these generally extend well below the cofferdam.

Inside excavation is usually done using clam shell buckets. In order to dewater the cofferdam, the bottom must be stable and able to resist hydrostatic uplift. Placement of an underwater concrete seal course is the fastest and most common method.

An underwater concrete seal course may then be placed prior to dewatering in order to seal off the water, resist its pressure, and also to act as a slab to brace against the inward movement of the sheet piles in order to mobilize their resistance to uplift under the hydrostatic pressure (Fig. 5)

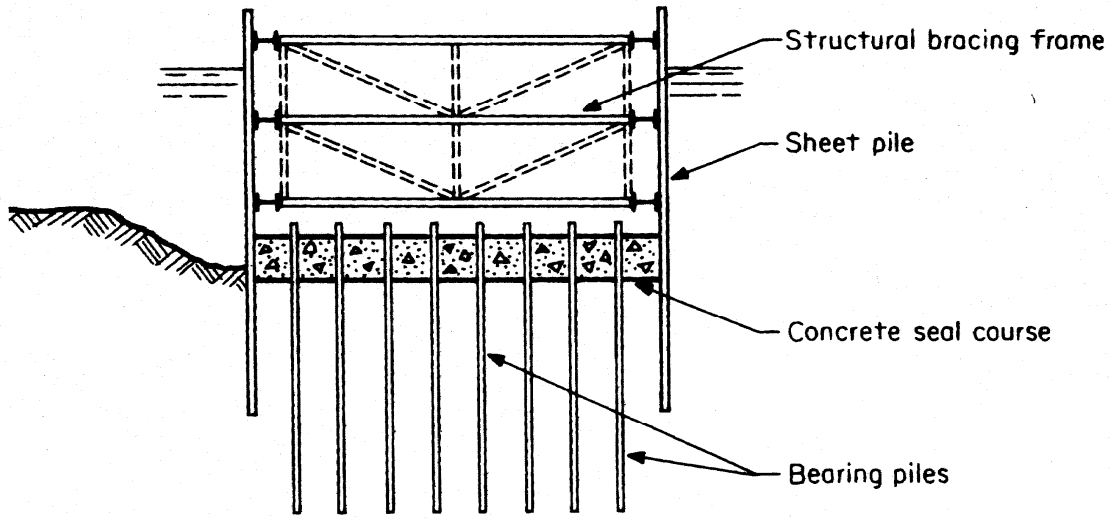

Figure 5 – Typical cofferdam (with seal)

5. COFFERDAM CONSTRUCTION SEQUENCE:

For a typical cofferdam, such as for a bridge pier, the construction procedure follow the listed pattern.

1. Pre-dredge to remove soil or soft sediments and level the area of the cofferdam (Fig. 6a).
2. Drive temporary support piles (Fig. 6b).
3. Temporarily erect bracing frame on the support piles (Fig. 6b).
4. Set steel sheet piles, starting at all four corners and meeting at the center of each side (Fig. 6c).
5. Drive sheet piles to grade (Fig. 6c).
6. Block between bracing frame and sheets, and provide ties for sheet piles at the top as necessary (Fig. 6c).
7. Excavate inside the grade or slightly below grade, while leaving the cofferdam full of water (Fig. 7a).
8. Drive bearing piles (Fig. 7b).
9. Place rock fill as a leveling and support course (Fig. 7b).
10. Place tremie concrete seal (Fig. 7c).

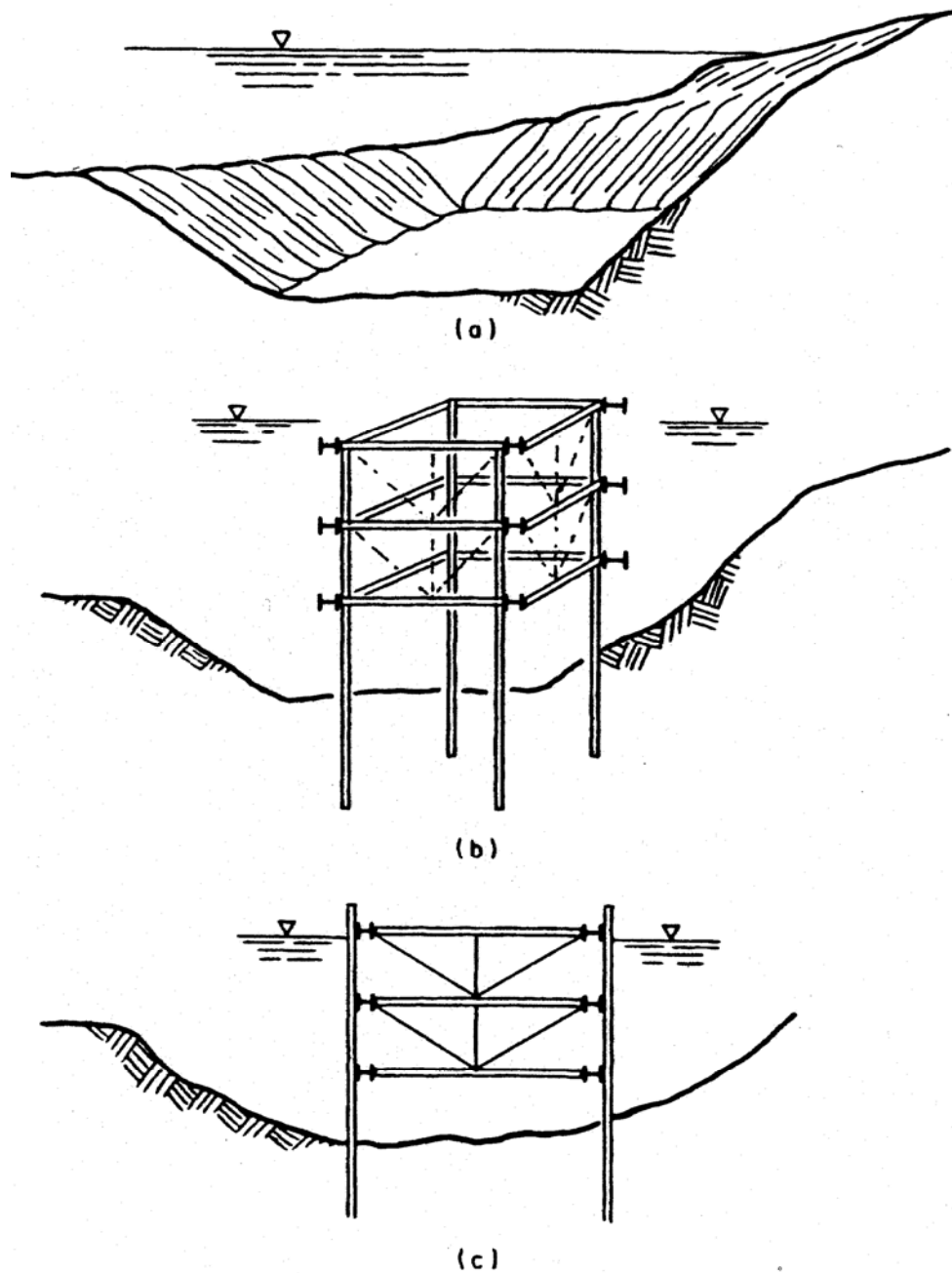

Figure 6 – Cofferdam construction sequence (I). (a) Pre-dredge. (b) Drive support piles; set prefabricated bracing frame and hang from support piles. (c) Set sheet piles; drive sheet piles; block and tie sheet piles to top wale.

11. Check blocking between bracing and sheets (Fig. 8a).
12. Dewater (Fig. 8a).
13. Construct new structure (Fig. 8a and b).

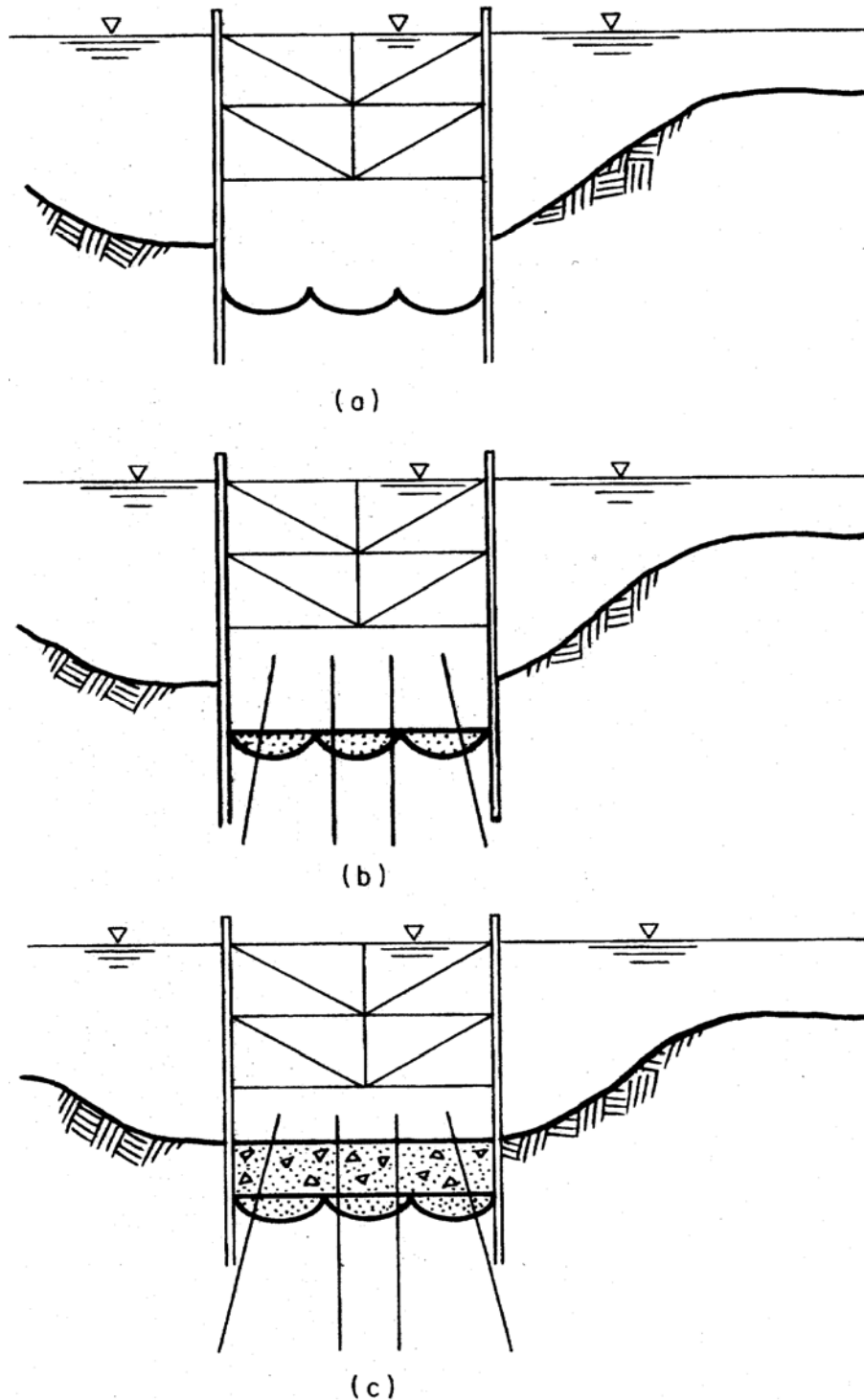

Figure 7 – Cofferdam construction sequence (II). (a) Excavate initial and final grade. (b) Drive bearing piles in place. (c) Place tremie concrete.

14. Flood cofferdam (Fig. 8b).
15. Remove sheet piles (Fig. 8c).
16. Remove bracing (Fig. 8c).
17. Backfill (Fig. 8c).

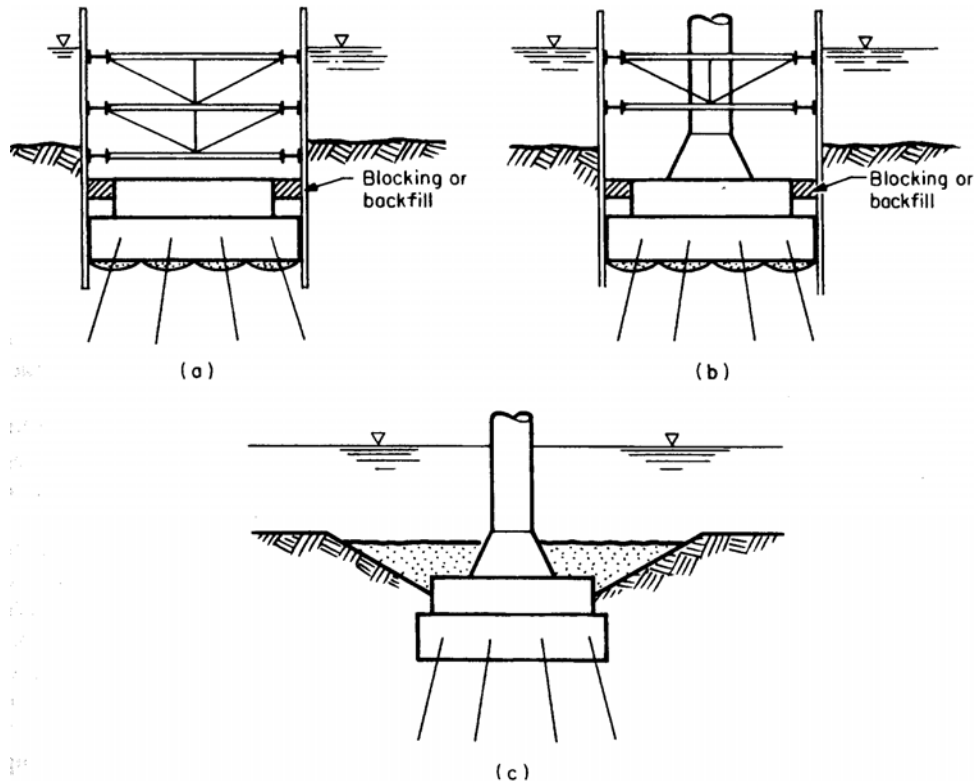

Figure 8 – Cofferdam construction sequence (III). (a) Check blocking; dewater; construct footing block; block between footing and sheet piles. (b) Remove lower bracing; construct pier pedestal; construct pier shaft. (c) Flood cofferdam; pull sheets; remove bracing; backfill.

Placement of the concrete seal is by tremie concrete:

The placement of tremie concrete (underwater concrete) is carried out through a tube, usually 10- to 12-in. pipe. This procedure was covered in lesson 3.

Traditional Sheet Pile Shapes

Z-Type (Z): Used for intermediate to deepwall construction, Z sections are considered one of the most efficient piles available today. Z – Piles are commonly used for cantilevered and tied-back retaining systems. Additional applications also include load bearing bridge abutments. Figure 9 shows traditional sheet pile shapes and typical types of interlocks.



Larson / “U” Type (U): Used for applications similar to Z - Type



Flat / Straight Type (SA), (S): Used for filled cell construction



Arch shaped & lightweight : Used for shallower wall construction



Typical types of interlocks

Ball & Socket (BS):



Single Jaw (SJ)



Double Jaw (DJ)



Hook & Grip (HG)



Thumb & Finger

one point contact (TFX)



Double Hook (DH)



Thumb & Finger

three point contact (TF)



Figure 9 - Traditional sheet pile shapes and typical types of interlocks

Examples of cofferdams:

With the ring in place work at the bottom of the cofferdam can proceed in a dry and safe environment. The steel casing of the drilled shafts is cut off down to the level of the top of the seal and the bad concrete left in the casing during placing of the shaft is chipped out leaving good concrete and rebars that will extend into the footing making the foundation one solid unit. In Figure 10 see some of the chipped concrete at some caissons while others have yet to be chipped.



Figure 10 - Cofferdam for the Sidney Lanier Bridge, Oregon

Braced Cofferdam Construction

Figures 11 and 12 show the installation of wale and strut system for framework /template. Figure 13 shows pictures of an impact hammer and a vibratory pile driver.



Figure 11 – Installation of wale and strut system



Figure 12 – Installation of wale and strut system and driving the sheet piles

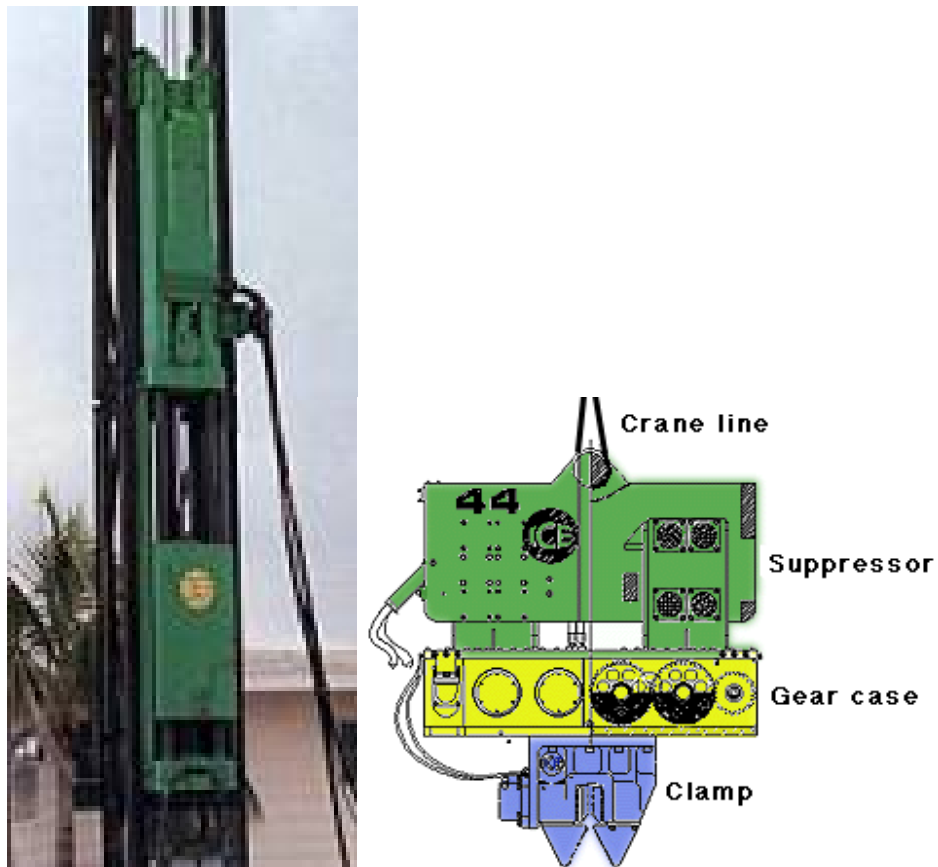

Figure 13 – An impact hammer and a vibratory pile driver

Tips for installing Sheet piles:

- Always set-up a template system
- Rule of thumb: Crane Boom length should be twice that of the sheets
- Drive the Sheets with the “male” interlock leading in order to avoid soil plugs
- If the “female” interlock must lead, place a bolt or other object at the bottom to avoid debris filling the slot
- Align and plumb the first two sheets and drive carefully and accurately
- Drive sheets in pairs when possible placing the hammer in the center of the pair
- Some contractors recommend not driving a sheet more than 1/3 its length before driving the adjacent pile
- Letting the sheets "freefall" and drop in order to aid in penetration will generally cause the sheets to fall "out of plumb"
- Cellular cofferdams require that all sheets are set and "closed" before any driving is done
- Finally... never rush the Pile Foreman!!

Lesson Summary

Every cofferdam is unique and requires thorough analysis. The designer must take into account a large number of parameters. The design must be compatible with the weather conditions, waves, currents, construction equipment, construction methods, internal permanent structures, and ground conditions. Comparable cost studies should be analyzed to determine if the cofferdam method is favored over other techniques, such as precast or caisson construction.